

INT62A

Preset Timer with LED Display & BCD Output Option

Features

- 6 Large, LED Digits
- Contact Closure, 3 to 30 Volt DC Start/Stop Pulse
- AC or DC Power
- Remote & Front Panel Reset
- Screw Terminal Connection
- NEMA 4X / IP65 Front Panel

Applications:

Ideal for elapsed time indication applications where a large LED display is required. Equipment or machinery downtime indicator/on-time indicator.

Description:

The INT62A is a low cost, highly accurate 6 digit timer. The large, brilliant .6" red-orange LED's show the elapsed time. If there is a failure of the AC or DC power source, an internal memory system will retain all of the important information for at least ten years without any battery. The unit is housed in a NEMA 4X/IP65 front, DIN standard panel mount enclosure. See "Timer Switch Settings" section for "Time Base" ranges. The keypad is used to divide the "Time Base" from 1 to 100, change the decimal point, key-in preset times and reset the timer.

Specifications:

Mounting: Standard DIN cut-out. 3.622" (92mm) wide, 1.772" (45mm) high, 4.4" (111.8mm) max depth behind panel.

Display: 6 digit, 0.55" High LED

Power Supply: 110 VAC 50/60 Hz., 220 VAC 50/60 Hz., 12 VDC - 10% to 24 VDC + 10%.

Accuracy: Over full temperature range, an accuracy of 0.05% is obtained by the use of an internal crystal time base oscillator.

+ 5 Volt DC Output: Up to 100mA of + 5 Volt regulated power is available to supply peripheral devices.

Power Consumption: Less than 425mA required for DC operation with all options. Less than 260mA without BCD output option. AC power consumption less than 5 watts with all options.

Standby System: Internal non-volatile RAM (EEPROM) retains counts for at least ten years without power.

Housing: Standard high impact UL94V-O rated plastic case.

Temperature: Operating + 32 °F (0°C) to + 130°F (+ 54°C). Storage -40°F (-40°C) to + 200°F (+ 93°C).

Signal input: 3 to 30 Volt DC pulses of .5 ms. minimum duration.

BCD Output: Parallel TTL 5VDC compatible positive true logic four lines per digit. Six full digits of data.



TIMER SWITCH SETTINGS:

Remove front bezel revealing DIP switches (see figure below). Set the switches to the desired function according to the programming instructions following: (OFF is up, ON is down)

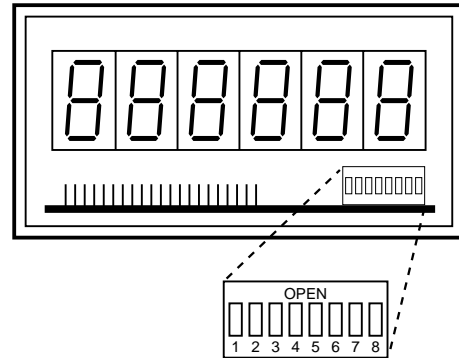

- SW 1 OFF Reset to zero
ON Reset to preset
- SW 2 OFF Level activation (continuous time)
ON Pulsed activation (start and stop on same line)
- SW 3 ON This switch must be in this position to be a timer. (if OFF it is a counter, see Preset Counter section)

SW 4, 5 Sets time base. (see below)

SW4	SW5	TIME BASE
OFF	OFF	Seconds and 1/100
ON	OFF	Minutes and 1/100
OFF	ON	Hours and 1/100
ON	ON	Minutes and seconds

- SW 6 OFF Outputs latched until reset
ON 250 mS. output (momentary)
- SW 7 OFF Display continues to count thru preset.
ON Display recycles at preset
- SW 8 OFF Timer will not stop if reset is activated.
ON Timer stops on reset and power recovery.

PRESET TIMERS

Terminal Designations:

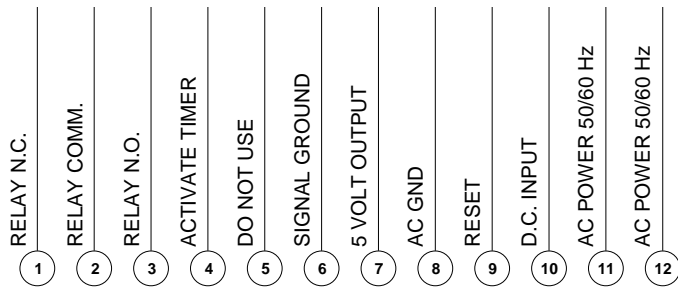

IMPORTANT:

Terminal #8 must be connected to earth ground at all times when in use. This provides a ground path for static electricity which otherwise would cause faulty operation, erroneous data or circuit damage.

BCD Option Terminal Designations:

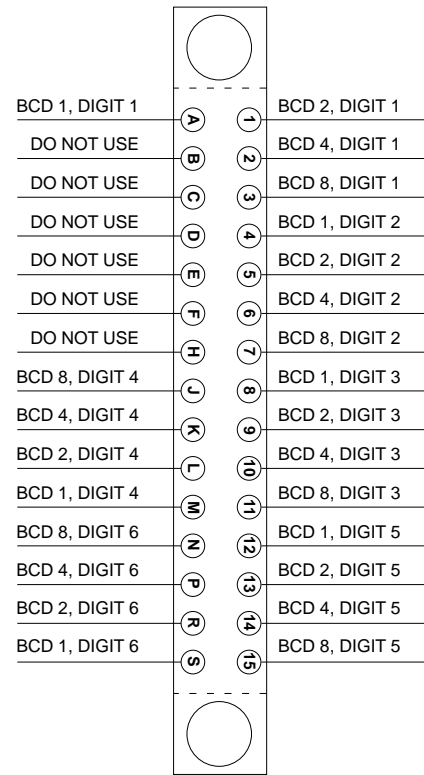

NOTE:

The BCD PCB edge connector consists of 30 gold plated and bifurcated solder connections. It is configured with two rows of 15 solder points labeled 1 to 15 and A to S. Each solder terminal will accept up to three soldered wires of #22 AWG.

PRESET TIMERS

Mounting:

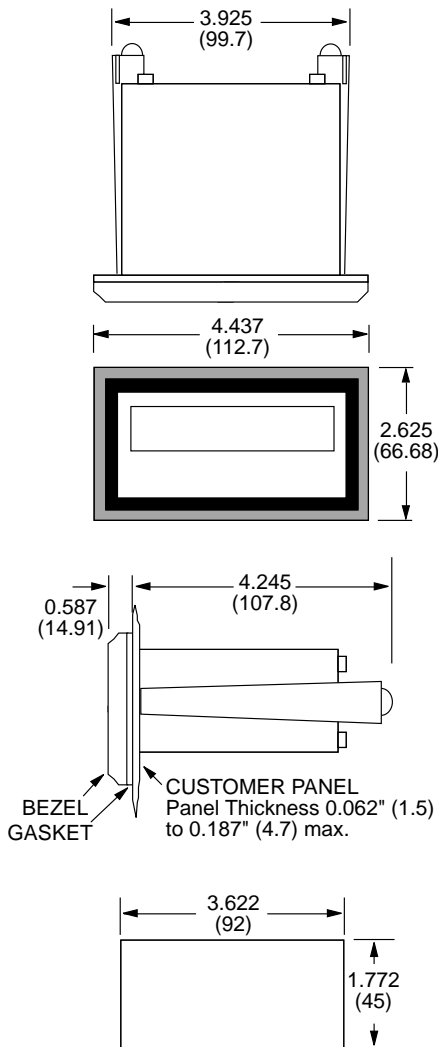

How To Order:

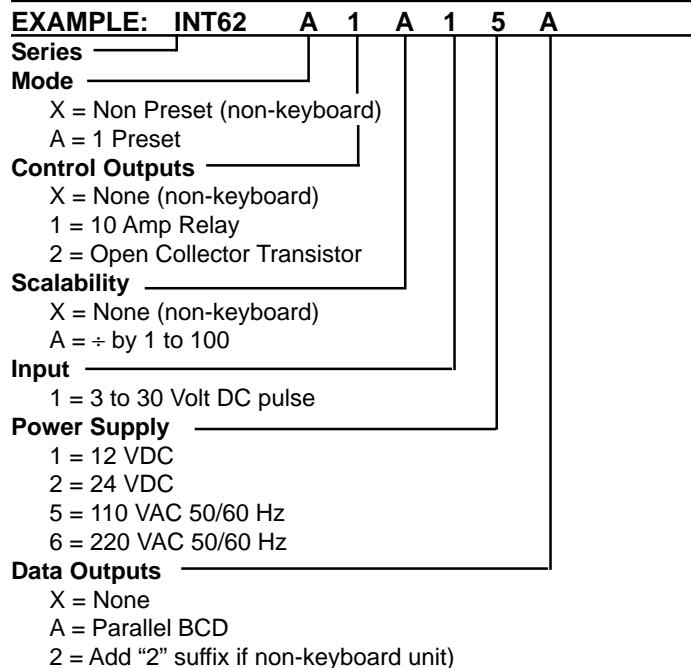

Accessories

Non keyboard panel separate: Model 34235
Keyboard panel Model 34236