

SERIES 1670 - SINGLE AND DOUBLE-POLE PUSHBUTTON SWITCHES

TO 16 (4) A 250 V AC

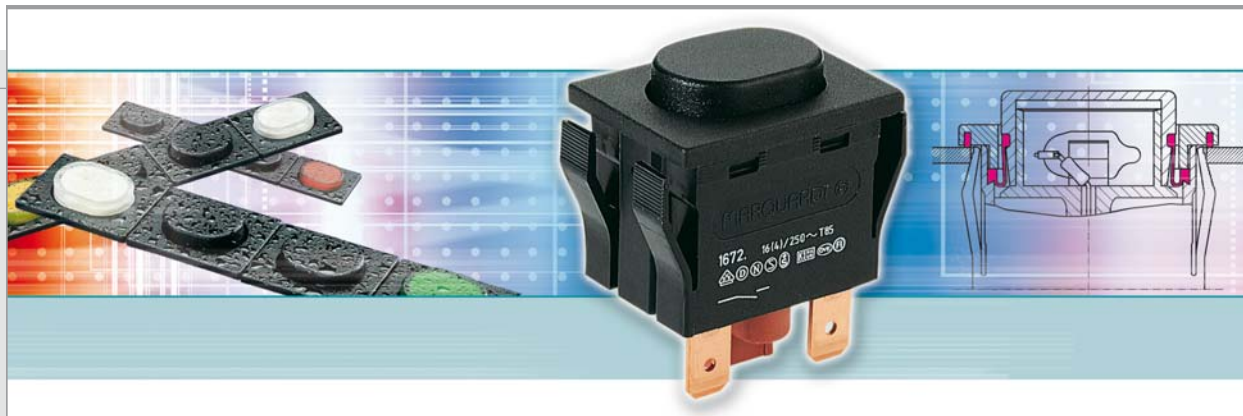

PRODUCT FEATURES

- ◆ Illuminated and non-illuminated pushbutton switch
- ◆ Internal gasket for IP 54
- ◆ Proven jump contact switching system (double interrupting)
- ◆ Opening and closing speed independent of the actuating speed
- ◆ Product-dependent with external lamp connection

ON REQUEST









































- ◆ Other colors
- ◆ Other printing variants
- ◆ Other connection types
- ◆ Other lamp variants
- ◆ Cable assembly

Mechanical life endurance	5E4
Operating force	ca. 8 N
Contact resistance (new condition)	< 100 mOhm (1 A 12 V DC)
Insulation resistance (new condition)	> 100 MOhm (500 V DC)
Voltage strength at 250 V	1 500 V function insulation / basic insulation 3 000 V reinforced insulation 500 V small contact distance
Proof tracking	250 PTI
Insulation spacing	acc. to EN 61058 for reinforced or double insulation
Protection type	IP 54
Ambient temperature	connection side -20 °C ... +85 °C actuating side -20 °C ... +55 °C
Flammability	UL 94 V-2
Heat and fire resistance	850 °C (category D)
Material	actuator PA / PC (product-dependent) housing PA / PA glass fiber-reinforced (product-dependent) connections Cu
Plug force of the terminals	≤ 80 N
Approval marks	
Suitable for appliances of protection class II	



SERIES 1670 - SINGLE AND DOUBLE-POLE PUSHBUTTON SWITCHES

TO 16 (4) A 250 V AC

 single-pole 	Voltage lamp in V	Actuator description	Housing color	16 (4) A 250 V AC 1E4	12 (4) A 250 V AC 1E4	Connection type	Connection description	Contact distance in mm	Contact material	Miscellaneous	Stock version
Normally open contact (SPNO)											
1675.5315	230			●			6.3 / 2 x 4.8	≥ 3	Ag	external lamp connection	
1672.5101				●			6.3	≥ 3	Ag		
Switch (SPDT)											
1673.5501					●		4.8	< 3	Ag		
double-pole											
 double-pole 	Voltage lamp in V	Actuator description	Housing color	16 (4) A 250 V AC 1E4	12 (4) A 250 V AC 1E4	Connection type	Connection description	Contact distance in mm	Contact material	Miscellaneous	Stock version
ON/OFF switch (SPST)											
1670.5201	230			●			6.3	≥ 3	Ag		●
1670.5202	230			●			6.3	≥ 3	Ag		●
1670.5204	230			●			6.3	≥ 3	Ag		
1670.5304	230			●			6.3 / 2 x 4.8	≥ 3	Ag	external lamp connection	
1670.5203	115 - 230			●			6.3	≥ 3	Ag		
1671.5201				●			6.3	≥ 3	Ag		●
1671.5203				●			6.3	≥ 3	Ag	cover gray	
Normally open contact (SPNO)											
1671.5101				●			6.3	≥ 3	Ag		
1671.5104				●			6.3	≥ 3	Ag		

ROCKER SWITCHES

PUSHBUTTON SWITCHES

TOGGLE SWITCHES

SLIDE SWITCHES

ROTARY SWITCHES

FOOT SWITCHES

POWER TOOL SWITCHES

TACT AND KEY SWITCHES

SNAP-ACTION SWITCHES









SWITCHES

SERIES 1670 - SINGLE AND DOUBLE-POLE PUSHBUTTON SWITCHES

TO 16 (4) A 250 V AC



Lamp

	Voltage lamp in V	Actuator description	Housing color	16 (4) A 250 V AC 1E4	12 (4) A 250 V AC 1E4	Connection type	Connection description	Contact distance in mm	Contact material	Miscellaneous	Stock version
Lamp											
1677.5306	230						6.3				
1677.5307	115 - 230						6.3				
1677.5308	115 - 230						6.3				

SERIES 1670 - SINGLE AND DOUBLE-POLE PUSHBUTTON SWITCHES

TO 16 (4) A 250 V AC



Basic types 1672, 1673 and 1675
single-pole
illuminated / non-illuminated

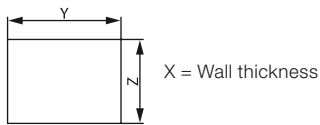

X	Y	Z
0.8 ... 5.0	30.0 +0.15	22.2 +0.15

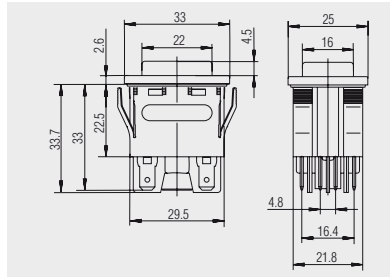

Quick-connect terminal 4.8
1673.5501

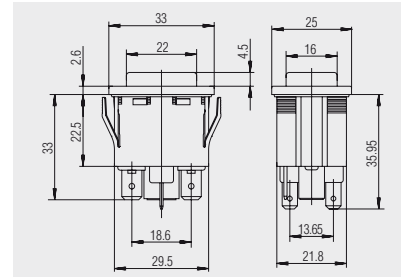

Quick-connect terminal 6.3 / 2 x 4.8
external lamp connection
basic type 1675

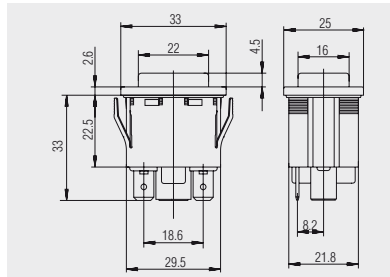

Quick-connect terminal 6.3
basic type 1672



Basic types 1670 and 1671
double-pole
illuminated / non-illuminated

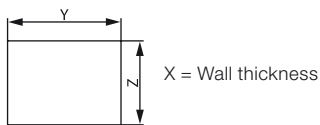

X	Y	Z
0.8 ... 5.0	30.0 +0.15	22.2 +0.15

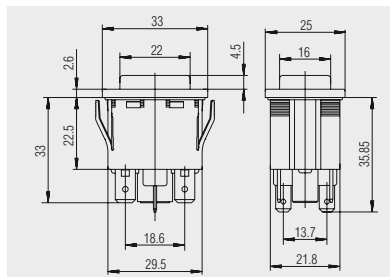

Quick-connect terminal 6.3 / 2 x 4.8
chromated external lamp
connection
1670.5304

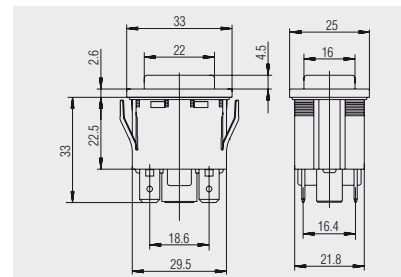

Quick-connect terminal 6.3
basic types 1670 and 1671

SERIES 1670 - SINGLE AND DOUBLE-POLE PUSHBUTTON SWITCHES

TO 16 (4) A 250 V AC

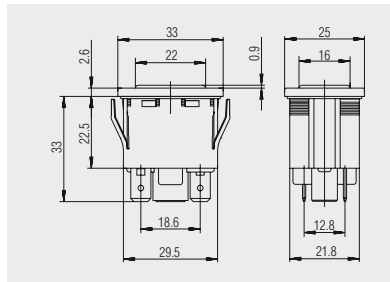

Quick-connect terminal 6.3

Basic type 1677
Lamp

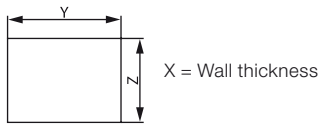

X	Y	Z
0.8 ... 5.0	30 ^{+0.15}	22.2 ^{+0.15}

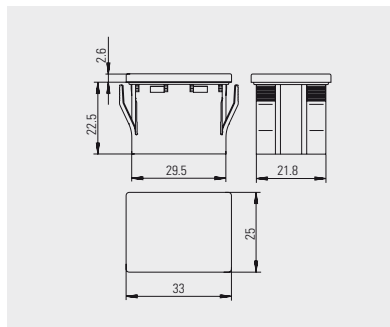

Dummy piece for size of basic type 1677 of PA with housing in black and cover in blue

Dummy piece
203.020.013

PRECISION SALES INC
 38 Bishop Hollow Rd
 Newtown Square PA 19073
www.precisionales.com
eparts@precisionales.com
 Fax : 610-353-1674
 610-359-1002